

VT6ED * Y - 066 - B38 1 R 00 - C 1 *

Series

M= Mobile 1 shaft seal

P= Mobile 2 shaft seal

Y - Metric port connection, Omit for UNC

Cam ring for "P1"

Volumetric displacement cm³/rev (in³/rev)

*042/R42 = 132.3 (8.07) 062/R62 = 196.7 (12.00)

045/R45 = 142.4 (8.69) 066/R66 = 213.3 (13.02)

050/R50 = 158.5 (9.67) 072/R72 = 227.1 (13.86)

052/R52 = 164.8 (10.06) 085/R85 = 269.8 (16.46)

057/R57 = 180.7 (11.02)

*'R' - for Mobile - spring assisted

Cam ring for "P2"

Volumetric displacement cm³/rev (in³/rev)

* B14/R14 = 47.6 (2.90) B35/R35 = 110.0 (6.77)

B17/R17 = 58.2 (3.55) B38/R38 = 120.3 (7.34)

B20/R20 = 66.0 (4.03) B42/R42 = 136.0 (8.30)

B24/R24 = 79.5 (4.85) B45/R45 = 145.7 (8.89)

B28/R28 = 89.7 (5.47) B50/R50 = 158.0 (9.64)

B31/R31 = 98.3 (6.00) B61/R61 = 190.5 (11.62)

*'B' - for Mobile 'R' - for Mobile - spring assisted

Modifications

Seal class

1 - S1 (for mineral oil)

4 - S4 (for fire resistant fluids)

5 - S5 (for mineral oil and fire resistant fluids)

Design letter

Porting combination (see page BM-1-5)

00 - standard

Direction of rotation (view on shaft end)

R - clockwise

L - counter-clockwise

Type of shaft

P version

3 - Splined (no SAE)

Type of shaft

1 - keyed (SAE CC)

2 - keyed (no SAE)

3 - splined (SAE C)

4 - splined (SAE CC)

T - Splined (SAE J718c)

VP
DP

INTERNAL LEAKAGE (TYPICAL)

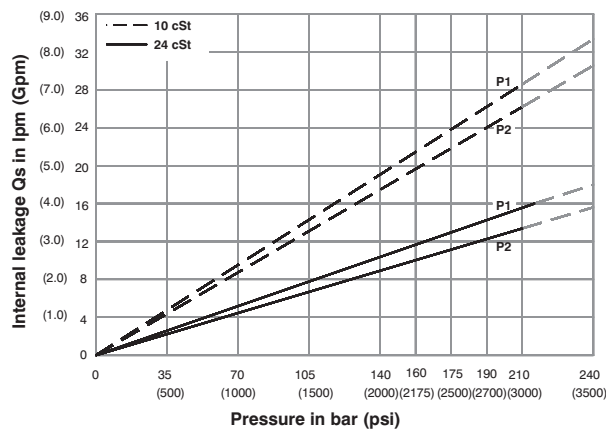

Do not operate pump more than 5 seconds at any speed or viscosity if internal leakage is more than 50% of theoretical flow. Total leakage is the sum of each section loss at its operating conditions.

NOISE LEVEL (TYPICAL)

VT6EDM-050-B38

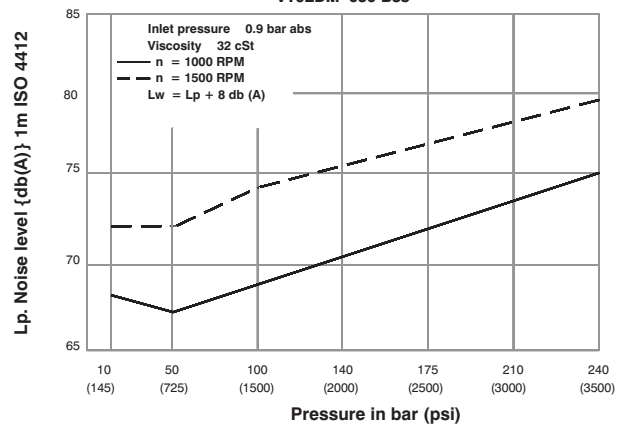

Double pump noise level is given with each section discharging at the pressure noted on the curve.

HYDROMECHANICAL POWER LOSS (TYPICAL)

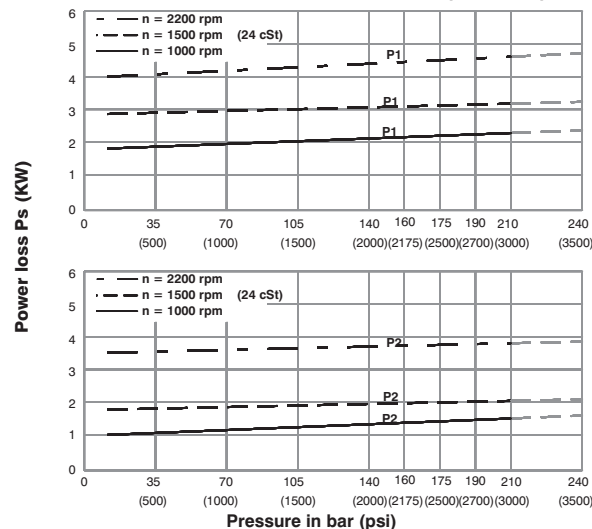

Total hydromechanical power loss is the sum of each section at its operating conditions.

PERMISSIBLE RADIAL LOAD

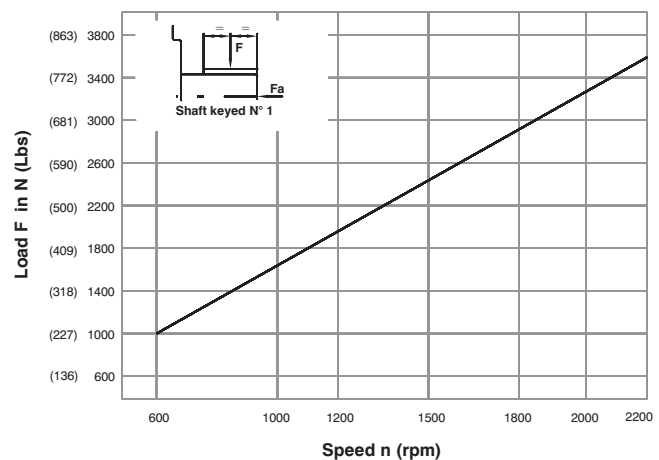

Maximum permissible axial load Fa = 2000 N (449 Lbs)

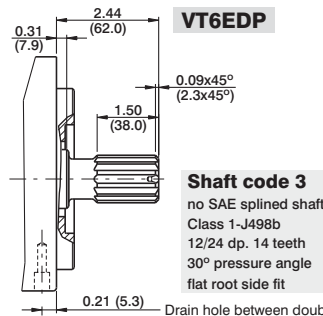
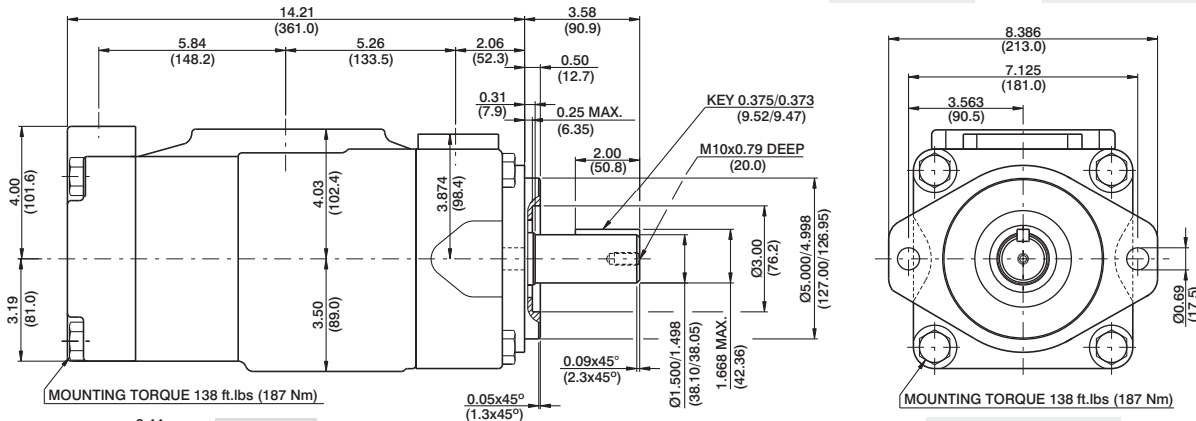
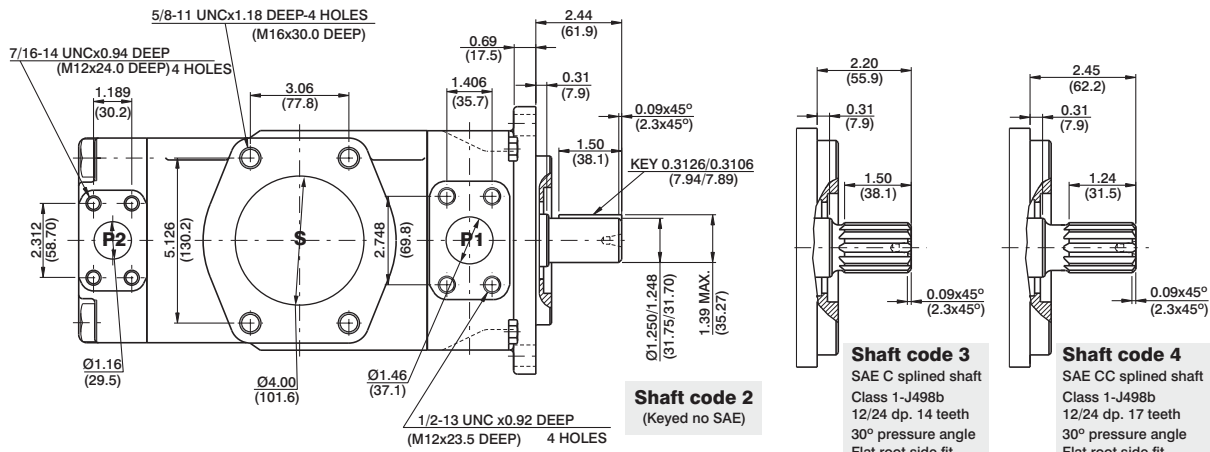

Shaft torque limits in ³ /rev x psi (ml/rev x bar)	
Shaft	Vp x p max. (P1+P2)
1	64044 (72306)
2	30638 (34590)
3	54207 (61200)
4	67582 (76376)
T	63256 (70400)
(VT6EDP) 3	54207 (61200)

OPERATING CHARACTERISTICS - TYPICAL (24 cST) (Input power p (KW) for one cartridge only)

Pressure port	Series	Volumetric Displacement Vp		Flow q & n = 1500 rpm						Input power p & n = 1500 rpm					
		p = 0 bar (0 psi)		p = 140 bar (2000 psi)		p = 240 bar (3500 psi)		p = 7 bar (100 psi)		p = 140 bar (2000 psi)		p = 240 bar (3500 psi)			
		in ³ /rev	cm ³ /rev	gpm	lpm	gpm	lpm	gpm	lpm	hp	kw	hp	kw	hp	kw
P1	042	8.07	132.3	52.50	198.5	49.87	188.5	47.96	181.3	6.97	5.2	66.25	49.4	110.77	82.6
	045	8.70	142.4	56.51	213.6	53.86	203.6	51.98	196.5	7.24	5.4	70.94	52.9	118.95	88.7
	050	9.67	158.5	62.88	237.7	60.24	227.7	58.36	220.6	7.64	5.7	78.45	58.5	131.82	98.3
	052	10.00	164.8	65.40	247.2	62.75	237.2	60.87	230.1	7.78	5.8	81.53	60.8	136.92	102.1
	057	11.02	180.7	71.71	271.1	69.07	261.1	67.19	254.0	8.18	6.1	89.04	66.4	143.35	106.9
	062	12.00	196.7	78.04	295.0	75.40	285.0	73.52	277.9	8.58	6.4	96.42	71.9	162.67	121.3
	066	13.00	213.3	84.63	319.9	81.98	309.9	80.11	302.8	8.98	6.7	104.20	77.7	175.94	131.2
	072	13.86	227.1	90.11	340.6	87.46	330.6	85.58	323.5	9.25	6.9	110.77	82.6	187.07	139.5
	085 ^{1,2)}	16.40	269.8	107.00	404.7	105.21	397.7	--	--	9.78	7.3	87.56	65.3	--	--
P2	B14	2.90	47.6	18.88	71.4	16.42	62.1	14.78	55.9	3.08	2.3	24.81	18.5	41.03	30.6
	B17	3.55	58.2	23.1	87.3	20.6	78.0	18.99	71.8	3.35	2.5	29.77	22.2	49.62	37.0
	B20	4.00	66.0	26.19	99.0	23.73	89.7	22.08	83.5	3.75	2.8	33.39	24.9	55.92	41.7
	B24	4.80	79.5	31.56	119.3	29.10	110.0	27.46	103.8	4.02	3.0	39.69	29.6	66.78	49.8
	B28	5.50	89.7	35.58	134.5	33.12	125.2	31.48	119.0	4.29	3.2	44.52	33.2	74.96	55.9
	B31	6.00	98.3	39.00	147.5	36.53	138.1	34.89	131.9	4.42	3.3	48.54	36.2	81.80	61.0
	B35	6.80	111.0	44.04	166.5	41.58	157.2	39.94	151.0	4.69	3.5	54.58	40.7	92.13	68.7
	B38	7.30	120.3	47.72	180.4	45.26	171.1	43.62	164.9	4.96	3.7	58.87	43.9	99.64	74.3
	B42	8.30	136.0	53.96	204.0	51.50	194.7	49.86	188.5	5.36	4.0	66.25	49.4	112.24	83.7
	B45	8.89	145.7	57.80	218.5	55.34	209.2	53.70	203.0	5.50	4.1	70.81	52.8	120.02	89.5
	B50 ³⁾	9.64	158.0	62.69	237.0	60.23	227.7	59.25	224.0	5.90	4.4	76.44	57.0	123.98	93.0
B61 ⁴⁾	11.62	190.5	76.25	285.7	73.54	278.0	--	--	6.16	4.6	81.26	60.6	--	--	

1) 085 = 2000 RPM max.

2) 085 = 75 bar (1100 psi) cont. 085 = 90 bar (1300 psi) max. int.

3) B50=210 bar (3000 psi) max. int

4) B61 = 120 bar (1740 psi) max. int, B61 = 80 bar (1160 psi) cont.