

Modifications

Mounting W/connection variables

		P1=1" - S=3 ^{1/2} "		P1=1" - S=2 ^{1/2} " ¹⁾²⁾	
		1"	3/4" ¹⁾²⁾	1"	3/4" ¹⁾²⁾
code	Unc	00	01	10	11
	Metric	OM	W0	1M	W1

- 1) for 46 ml/rev max.
 - 2) for 126 ml/rev max.
 - The large cartridge must be always mounted in the front.
- Seal class**
- 1 - S1 (for mineral oil)
 - 4 - S4 (for fire resistant fluids)
 - 5 - S5 (for mineral oil and fire resistant fluids)

Design letter

Porting combination (see page BM-1-5)

00 - standard

Direction of rotation (view on shaft end)

- R - clockwise
- L - counter-clockwise

- Type of shaft**
- 1 - keyed (no SAE)
 - 3 - splined (SAE BB)
 - 5 - splined (SAE B)
- Severe duty**
- 2 - keyed (SAE BB)
 - B - keyed

VP
DP

INTERNAL LEAKAGE (TYPICAL)

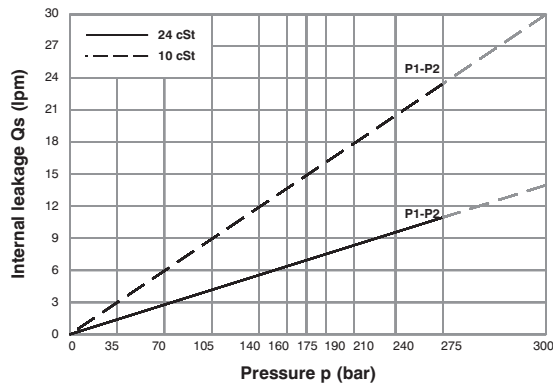

Do not operate pump more than 5 seconds at any speed or viscosity if internal leakage is more than 50% of theoretical flow. Total leakage is the sum of each section loss at its operating conditions.

NOISE LEVEL (TYPICAL)

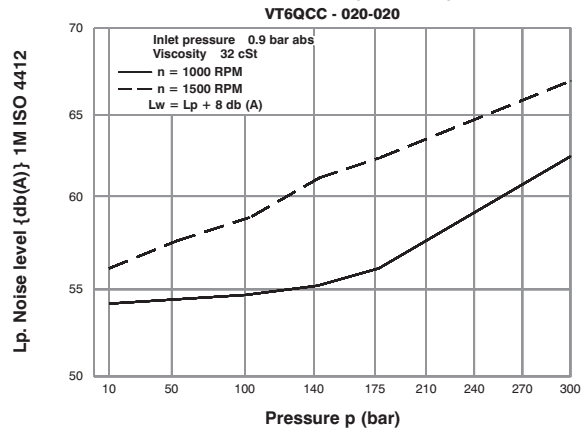

Double pump noise level is given with each section discharging at the pressure noted on the curve.

HYDROMECHANICAL POWER LOSS (TYPICAL)

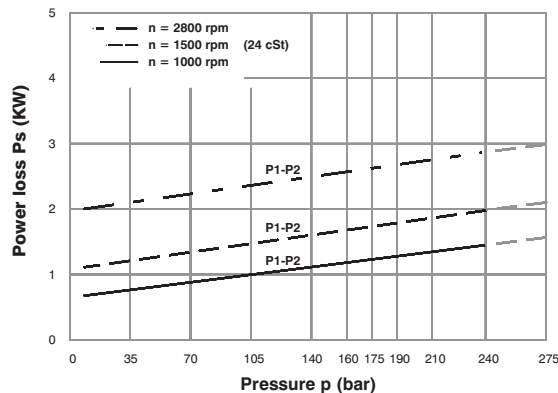

Total hydromechanical power loss is the sum of each section at its operating conditions.

PERMISSIBLE RADIAL LOAD

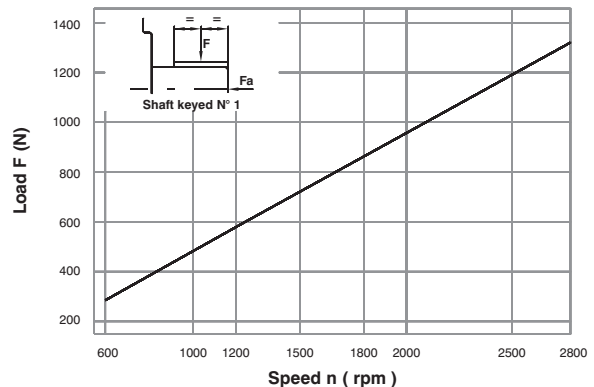

Maximum permissible axial load Fa = 800 N

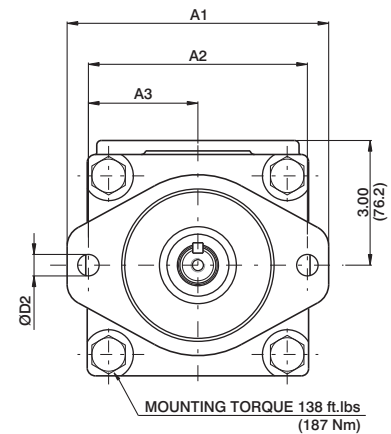
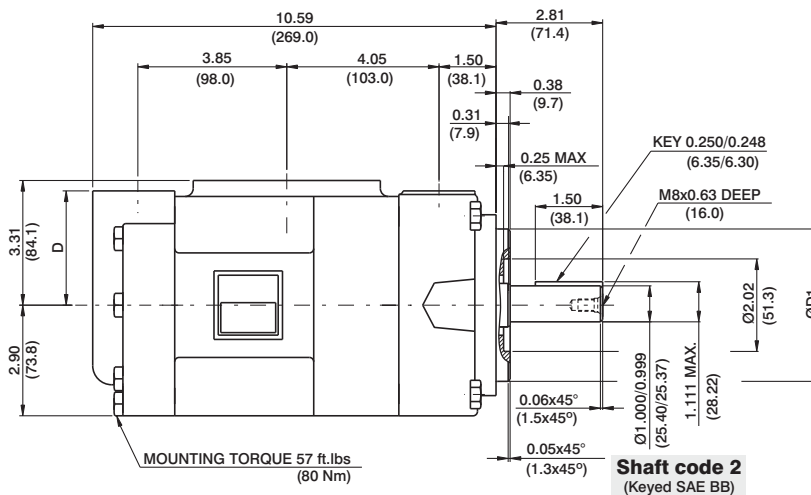
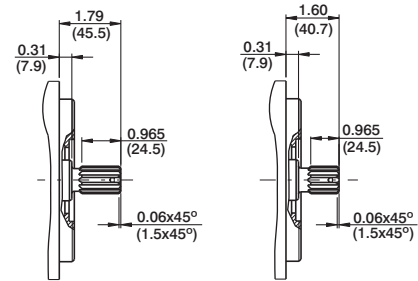
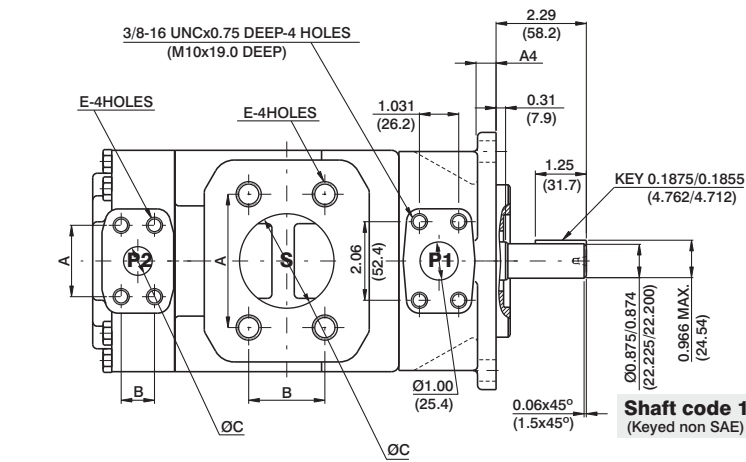

Shaft torque limits in³/revxpsi(ml/revxbar)

Shaft	Vp x p max. (P1+P2)
1	12666 (14300)
2	18972 (21420)
3	28937 (32670)
5	18246 (20600)

PORT	A	B	C	D	E
S	4.19 (106.4)	2.44 (61.9)	3.00 (76.2)		5/8-11UNCx1.12 DEEP (M16x28.4 DEEP)
S	3.50 (88.9)	2.00 (50.8)	2.50 (63.5)		1/2-13UNCx0.94 DEEP (M12x24.0 DEEP)
P2	1.874 (47.6)	0.874 (22.2)	0.75 (19.0)	3.00 (76.2)	3/8-16UNCx0.75 DEEP (M10x20.0 DEEP)
P2	2.06 (52.4)	1.03 (26.2)	1.00 (25.4)	2.94 (74.7)	

	VT7QCC1	VT7QCC2
Mounting	SAE B	SAE C
ØD1	4.000 (101.60) 3.998 (101.55)	5.000 (127.00) 4.997 (126.94)
ØD2	0.56 (14.3)	0.69 (17.5)
A1	6.87 (174.5)	8.36 (212.5)
A2	5.75 (146.0)	7.13 (181.0)
A3	2.87 (73.0)	3.56 (90.5)
A4	0.5 (12.7)	0.62 (15.7)

OPERATING CHARACTERISTICS - TYPICAL (24 cST) (Input power p (KW) for one cartridge only)

Series	Volumetric Displacement Vp	Flow q (lpm) & n = 1500 rpm				Input power p (kW) & n = 1500 rpm			
		p = 0 bar	p = 140 bar	p = 240 bar	p = 300 bar	p = 7 bar	p = 140 bar	p = 240 bar	p = 300 bar
003	10.8 ml/rev	16.2	11.9	8.1	--	1.3	5.3	7.8	--
005	17.2 ml/rev	25.8	21.5	17.7	13.7	1.4	7.5	12.2	14.9
006	21.3 ml/rev	31.9	26.5	22.0	18.0	1.5	8.9	14.7	18.0
008	26.4 ml/rev	39.6	34.1	29.6	25.6	1.6	10.7	17.7	21.8
010	34.1 ml/rev	51.1	45.7	41.2	37.2	1.7	13.4	22.3	27.5
012	37.1 ml/rev	55.6	50.2	45.7	41.7	1.7	14.4	24.1	29.8
014	46.0 ml/rev	69.0	63.5	59.0	55.0	1.9	17.6	29.5	36.5
015	50.5 ml/rev	75.1	69.6	65.1	61.1	2.0	18.0	32.0	39.5
017	58.3 ml/rev	87.4	82.0	77.5	73.5	2.1	19.0	36.9	45.7
020	63.8 ml/rev	95.7	90.2	85.7	81.7	2.2	23.8	40.2	49.8
022 ³⁾	70.3 ml/rev	105.4	100.0	95.5	91.5	2.3	26.1	44.1	50.3
025 ^{1,3)}	79.3 ml/rev	118.9	113.5	109.0	--	2.5	29.2	49.5	--
028 ^{1,4)}	88.8 ml/rev	133.2	127.7	124.5	--	2.8	32.7	48.5	--
031 ^{1,4)}	100.0 ml/rev	150.0	144.5	141.3	--	2.8	36.5	54.4	--

1) 025-028-031 = 2500 R.P.M. max. 2) 022 = 275 bar max. int. 3) 025 = 240 bar max. int. 4) 028-031 = 210 bar max. int.
-- Not to use because internal leakage greater than 50% of theoretical flow.