

VT7EB or VT7EBS - 042 - B12 - 1 R 00 - A 1 01 *

Series

VT7EB series-ISO 4 bolts 3019-2
Mounting flange 125-A2 HW

VT7EBS series- SAE C 2 bolts
Mounting flange J744c

Cam ring for "P1"

Volumetric displacement cm³/rev (in³/rev)

042 = 132.2 (8.07)	057 = 183.2 (11.18)
045 = 142.5 (8.70)	062 = 196.6 (12.0)
050 = 158.5 (9.67)	066 = 213.0 (13.0)
052 = 163.8 (10.0)	072 = 227.1 (13.86)
054 = 170.9 (10.43)	085 = 268.7 (16.40)

Cam ring for "P2"

Volumetric displacement cm³/rev (in³/rev)

B02 = 5.7 (0.35)	B09 = 28.0 (1.71)
B03 = 9.8 (0.60)	B10 = 31.8 (1.94)
B04 = 12.8 (0.78)	B11 = 34.9 (2.13)
B05 = 15.9 (0.97)	B12 = 40.9 (2.50)
B06 = 19.8 (1.21)	B14 = 45.1 (2.75)
B07 = 22.5 (1.37)	B15 = 50.0 (3.05)
B08 = 24.9 (1.52)	

Modifications

Mounting W/connection variables

P1=1-1/4" P2= 3/4" S=3-1/2"		
	VT7EBS	VT7EB-VT7EBS
Type	UNC	METRIC
code	01	M1

Seal class

- 1 - S1 (for mineral oil)
- 4 - S4 (for fire resistant fluids)
- 5 - S5 (for mineral oil and fire resistant fluids)

Design letter

Porting combination (see page BM-1-5)

00 - standard

Direction of rotation (view on shaft end)

- R - clockwise
- L - counter-clockwise

Type of shaft VT7EBS

- 1 - keyed (SAE CC) 3 - splined (SAE C)
- 2 - keyed (no SAE) 4 - splined (SAE CC)

Type of shaft VT7EB- VT7EBS
5 - keyed (ISO/R775 -G38M)

VP
DP

INTERNAL LEAKAGE (TYPICAL)

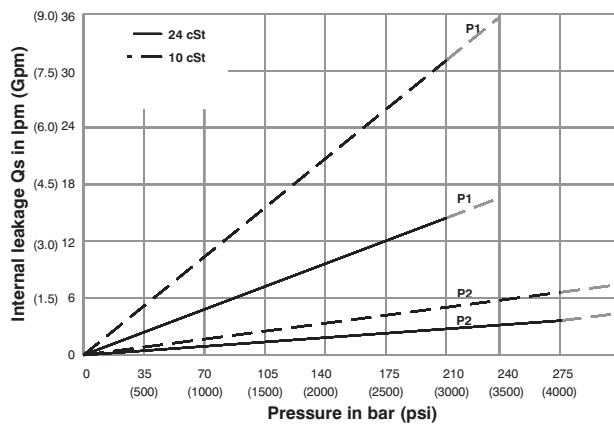

Do not operate pump more than 5 seconds at any speed or viscosity if internal leakage is more than 50% of theoretical flow. Total leakage is the sum of each section loss at its operating conditions.

NOISE LEVEL (TYPICAL)

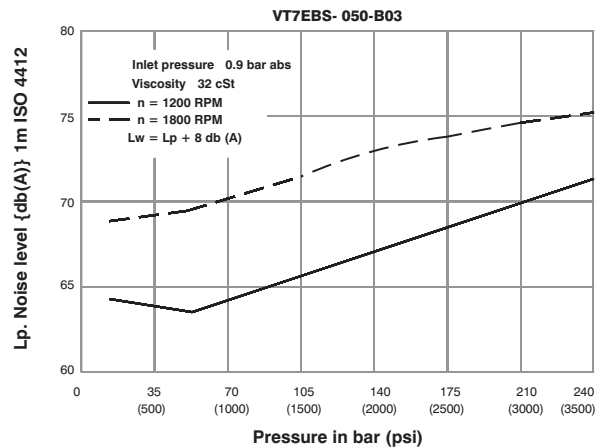

Double pump noise level is given with each section discharging at the pressure noted on the curve.

HYDROMECHANICAL POWER LOSS (TYPICAL)

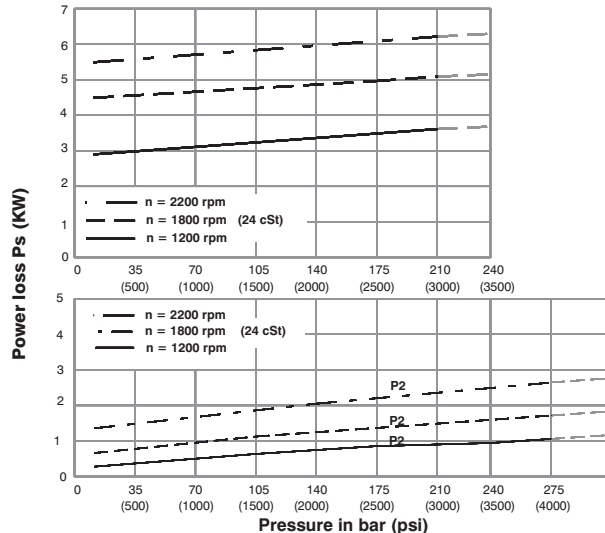

Total hydromechanical power loss is the sum of each section at its operating conditions.

PERMISSIBLE RADIAL LOAD

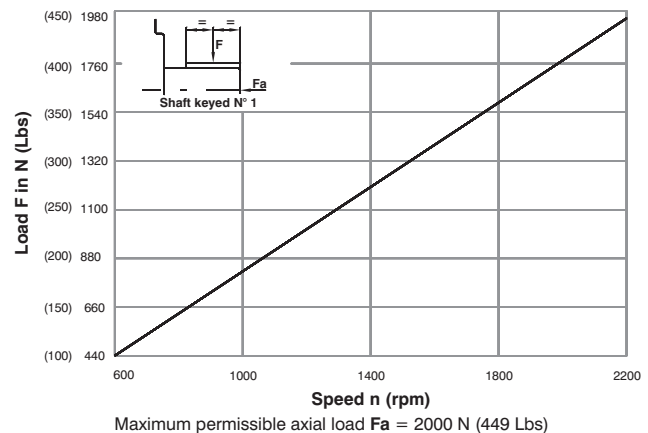

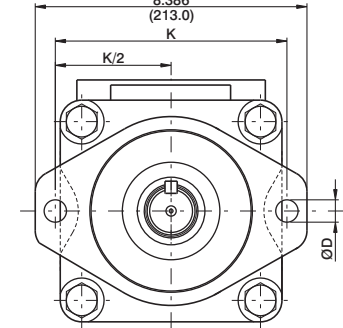
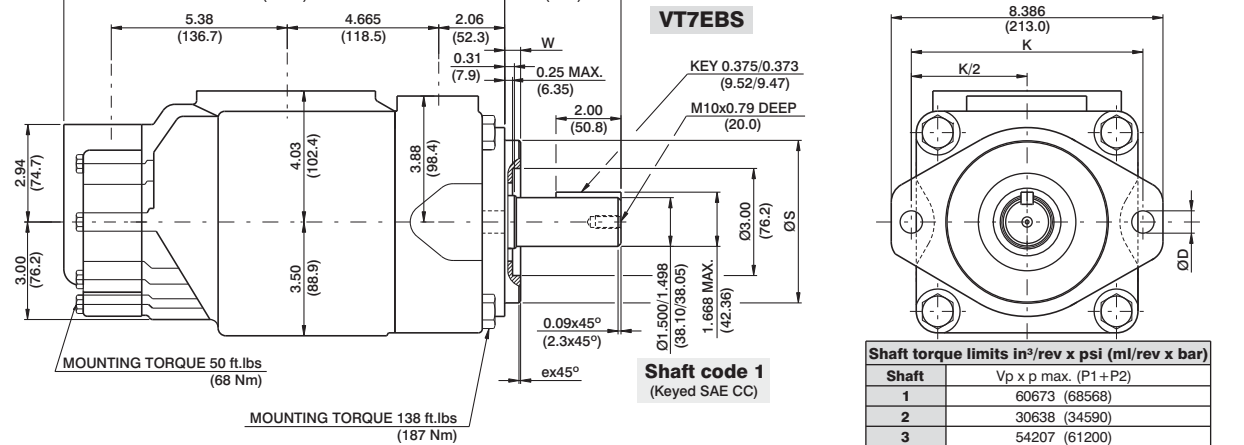
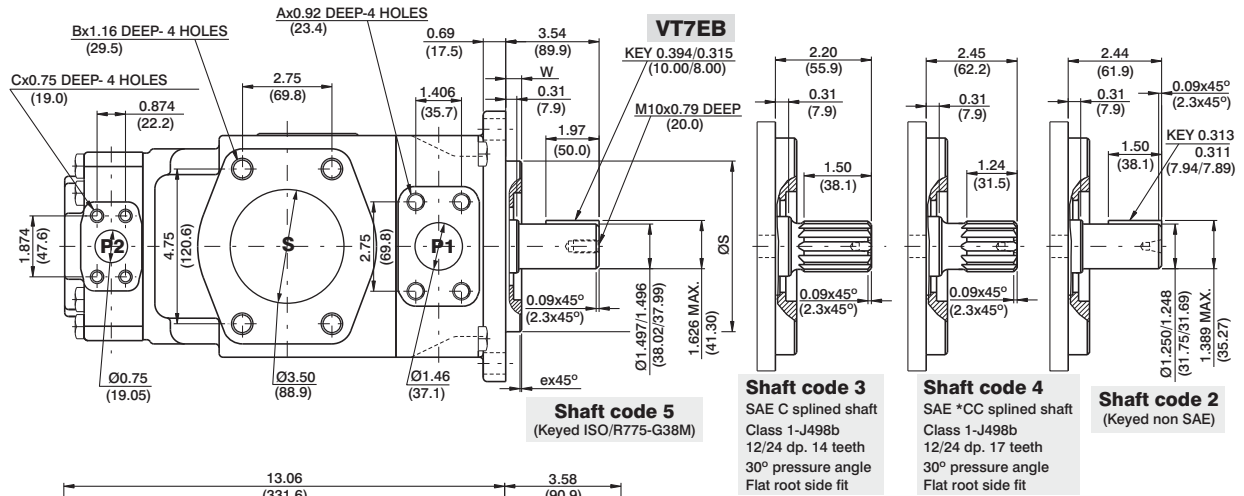

Shaft	Vp x p max. (P1+P2)
1	60673 (68568)
2	30638 (34590)
3	54207 (61200)
4	60673 (68568)
5	60673 (68568)

	O1	M1
A	1/2-13 UNC	M12
B	5/8-11 UNC	M16
C	3/8-16 UNC	M10

Series	ØS		ex45°	W	K	ØD
	MAX.	Min.				
VT7EB	4.921 (124.99)	4.919 (124.94)	0.079 (2.0)	0.374 (9.49)	7.087 (180.0)	0.709 (18.0)
VT7EBS	5.00 (127.00)	4.998 (126.94)	0.051 (1.3)	0.50 (12.7)	7.126 (181.0)	0.689 (17.5)

OPERATING CHARACTERISTICS - TYPICAL (24 cST) (Input power p (KW) for one cartridge only)

Pressure port	Series	Volumetric Displacement Vp		Flow q & n = 1800 rpm						Input power p & n = 1800 rpm					
		in ³ /rev	cm ³ /rev	p = 0 bar (0 psi)		p = 140 bar (2000 psi)		p = 240 bar (3500 psi)		p = 7 bar (100 psi)		p = 140 bar (2000 psi)		p = 240 bar (3500 psi)	
				gpm	lpm	gpm	lpm	gpm	lpm	hp	kw	hp	kw	hp	kw
P1	042	8.07	132.2	62.92	237.8	60.37	228.2	58.52	221.2	8.09	6.03	78.44	58.49	133.80	99.77
	045	8.70	142.5	67.72	255.9	65.17	246.3	63.32	239.3	8.37	6.24	84.04	62.66	143.60	107.08
	050	9.67	158.5	75.38	284.9	72.83	275.3	70.98	268.3	8.82	6.58	92.97	69.32	159.24	118.75
	052	10.00	163.8	78.37	296.2	75.82	286.6	73.97	279.6	8.99	6.70	96.47	71.94	165.36	123.31
	054	10.43	170.9	81.27	307.2	78.72	297.6	76.87	290.6	9.17	6.84	99.75	74.38	177.46	132.33
	057	11.18	183.2	87.12	329.3	84.57	319.7	82.72	312.7	9.51	7.09	106.57	79.47	189.84	141.56
	062	12.00	196.6	93.54	353.6	90.99	343.9	89.14	336.9	9.88	7.37	114.17	85.13	196.34	146.41
	066	13.00	213.0	101.44	383.4	98.89	373.8	97.04	366.8	10.34	7.71	123.38	92.0	212.46	158.43
	072	13.86	227.1	108.00	408.2	105.45	398.6	103.60	391.6	10.72	7.99	131.04	97.71	225.86	166.42
	085 ¹⁾	16.40	268.7	127.79	483.0	126.13	476.7	--	--	11.88	8.85	101.66	75.80	--	--
P2	B02	0.35	5.7	2.76	10.4	2.33	8.8	1.80	6.8	0.74	0.55	4.02	2.99	8.10	6.04
	B03	0.60	9.8	4.66	17.6	4.23	15.9	3.70	14.0	0.85	0.63	6.24	4.65	12.93	9.64
	B04	0.78	12.8	6.09	23.0	5.66	21.4	5.13	19.4	0.94	0.70	7.90	5.89	16.55	12.34
	B05	0.97	15.9	7.56	28.6	7.13	26.9	6.60	25.0	1.02	0.76	9.62	7.17	20.29	15.13
	B06	1.21	19.8	9.42	35.6	8.99	33.9	8.46	32.0	1.13	0.84	11.79	8.79	25.00	18.64
	B07	1.37	22.5	10.70	40.4	10.27	38.8	9.74	36.8	1.20	0.89	13.29	9.91	28.26	21.07
	B08	1.52	24.9	11.84	44.7	11.41	43.1	10.88	41.1	1.27	0.94	14.62	10.90	31.15	23.22
	B09	1.71	28.0	13.31	50.3	12.87	48.6	12.35	47.0	1.36	1.01	16.35	12.19	34.92	26.03
	B10	1.94	31.8	15.12	57.2	14.69	55.5	14.16	53.5	1.46	1.09	18.45	13.76	39.48	29.44
	B11 ²⁾	2.13	34.9	16.64	62.9	16.19	61.2	15.68	59.3	1.55	1.15	20.17	15.04	43.22	32.23
	B12 ²⁾	2.50	40.9	19.50	73.7	19.07	72.1	18.54	70.1	1.72	1.28	23.55	17.56	50.58	37.71
	B14 ²⁾	2.75	45.1	21.40	80.8	20.95	79.2	20.44	77.0	1.83	1.36	25.80	19.23	55.48	41.37
	B15 ²⁾	3.05	50.0	23.78	89.8	23.35	88.3	22.88	86.5	1.97	1.47	28.55	21.28	57.35	42.76

1) 085 = 90 bar (1300 psi) max.int. & 085 = 2000 rpm max. 2) B11-B12-B14 = 300 bar (4350 psi) & B15 = 280 bar (4060 psi) max. int. And Max. Speed = 3000 rpm