

VT67EC - 062 - 010 1 R 00 - A 1 00 - \*

**Series**-SAE C 2 bolts  
Mounting flange J744c

**Cam ring for "P1"**

Volumetric displacement  $\text{cm}^3 / \text{rev}$  ( $\text{in}^3 / \text{rev}$ )

042 = 132.2 (8.07)	057 = 183.2 (11.18)
045 = 142.5 (8.70)	062 = 196.6 (12.00)
050 = 158.5 (9.67)	066 = 213.0 (13.00)
052 = 163.8 (10.00)	072 = 227.1 (13.86)
054 = 170.9 (10.43)	085 = 268.7 (16.40)

**Cam ring for "P2"**

Volumetric displacement  $\text{cm}^3 / \text{rev}$  ( $\text{in}^3 / \text{rev}$ )

003 = 10.8 (0.66)	015 = 50.5 (3.08)
005 = 17.2 (1.05)	017 = 58.3 (3.56)
006 = 21.3 (1.30)	020 = 63.8 (3.89)
008 = 26.4 (1.61)	022 = 70.3 (4.29)
010 = 34.1 (2.08)	025 = 79.3 (4.84)
012 = 37.1 (2.26)	028 = 88.8 (5.42)
014 = 46.0 (2.81)	031 = 100.0 (6.10)

**Type of shaft**

- 1 - keyed (SAE CC)
- 2 - keyed (no SAE)
- 3 - splined (SAE C)
- 4 - splined (SAE CC)

**Modifications**

**Mounting W/connection variables**  
4 bolts SAE flange J518

P1 = 1 1/2" & S = 3 1/2"			
TYPE	Metric thread	UNC thread	
CODE	M0	M1	00 01
P2	1"	3/4"	1" 3/4"

**Seal class**

- 1 - S1 (for mineral oil)
- 4 - S4 (for fire resistant fluids)
- 5 - S5 (for mineral oil and fire resistant fluids)

**Design letter**

**Porting combination (see page BM-1-5)**

00 - standard

**Direction of rotation (view on shaft end)**

- R - clockwise
- L - counter-clockwise

**NOISE LEVEL ( TYPICAL )**  
VT67EC- 050-022

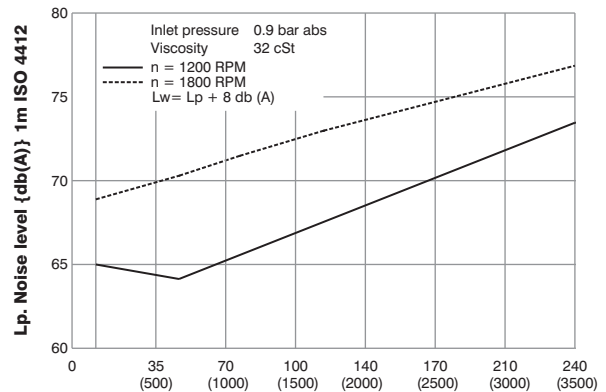

Double pump noise level is given with each section discharging at the pressure noted on the curve.

**INTERNAL LEAKAGE ( TYPICAL )**

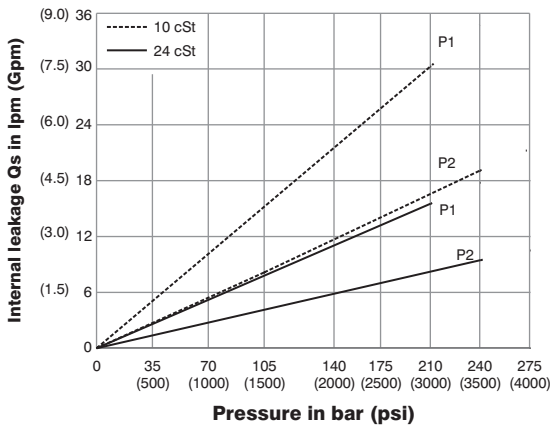

Do not operate pump more than 5 seconds at any speed or viscosity if internal leakage is more than 50 of theoretical flow.  
Total leakage is the sum of each section loss at its operating conditions.

**HYDROMECHANICAL POWER LOSS ( TYPICAL )**

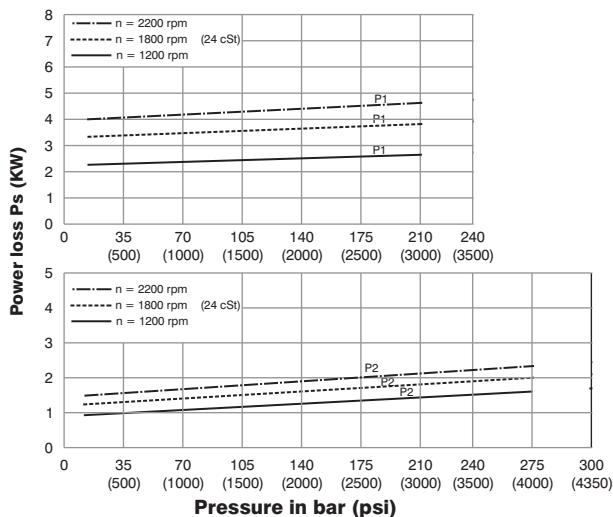

Total hydromechanical power loss is the sum of each section at its operating conditions.

**PERMISSIBLE RADIAL LOAD**

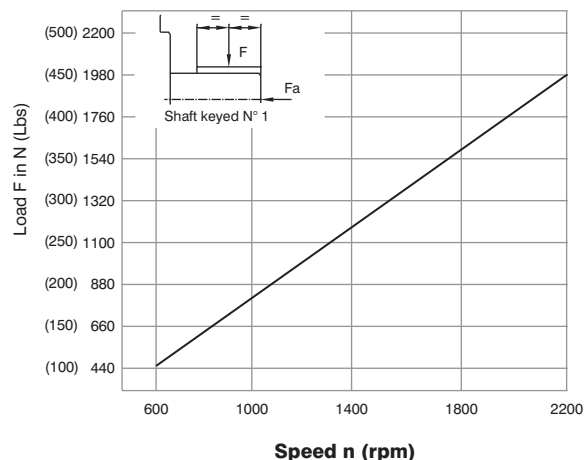

Maximum permissible axial load  $F_a = 2000 \text{ N}$  (449 Lbs)

Note: Product details are liable to change without any notice

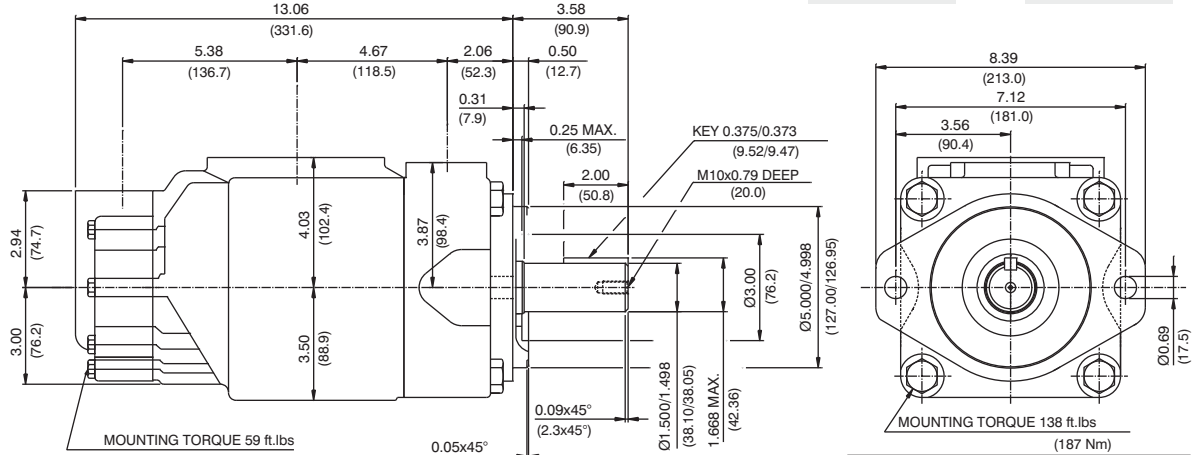
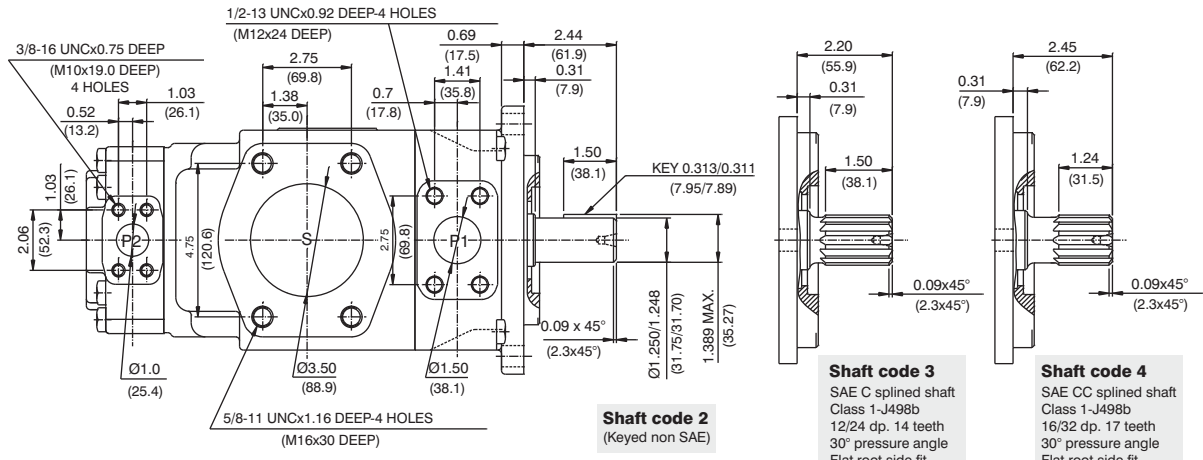

Shaft torque limits in <sup>3</sup> /rev x psi (ml/rev x bar)	
Shaft	Vp x p max. (P1+P2)
1	64039 (72306)
2	30638 (34590)
3	54207 (61200)
4	67582 (76376)

## OPERATING CHARACTERISTICS - TYPICAL (24 cST) (Input power p (KW) for one cartridge only)

Pressure port	Series	Volumetric Displacement Vp		Flow q & n = 1800 rpm						Input power p & n = 1800 rpm					
				p = 0 bar (0 psi)		p = 140 bar (2000 psi)		p = 240 bar (3500 psi)		p = 7 bar (100 psi)		p = 140 bar (2000 psi)		p = 240 bar (3500 psi)	
		in <sup>3</sup> /rev	cm <sup>3</sup> /rev	gpm	lpm	gpm	lpm	gpm	lpm	hp	kw	hp	kw	hp	kw
P1	042	8.07	132.2	62.92	237.8	60.37	228.2	58.52	221.2	8.09	6.03	78.44	58.49	133.80	99.77
	045	8.70	142.5	67.72	255.9	65.17	246.3	63.32	239.3	8.37	6.24	84.04	62.66	143.60	107.08
	050	9.67	158.5	75.38	284.9	72.83	275.3	70.98	268.3	8.82	6.58	92.97	69.32	159.24	118.75
	052	10.00	163.8	78.37	296.2	75.82	286.6	73.97	279.6	8.99	6.70	96.47	71.94	165.36	123.31
	054	10.43	170.9	81.27	307.2	78.72	297.6	76.87	290.6	9.17	6.84	99.75	74.38	177.46	132.33
	057	11.18	183.2	87.12	329.3	84.57	319.7	82.72	312.7	9.51	7.09	106.57	79.47	189.84	141.56
	062	12.00	196.6	93.54	353.6	90.99	343.9	89.14	336.9	9.88	7.37	114.17	85.13	196.34	146.41
	066	13.00	213.0	101.44	383.4	98.89	373.8	97.04	366.8	10.34	7.71	123.38	92.01	212.46	158.43
	072	13.86	227.1	108.00	408.2	105.45	398.6	103.60	391.6	10.72	7.99	131.04	97.71	225.86	166.42
085 <sup>1,2)</sup>	16.40	268.7	127.79	483.0	126.13	476.7	--	--	11.88	8.85	101.66	75.80	--	--	
P2	003	0.66	10.8	5.14	19.6	3.85	14.6	--	--	2.11	1.57	8.45	6.30	--	--
	005	1.05	17.2	8.18	30.9	6.89	26.0	5.68	21.5	2.29	1.70	12.00	8.94	19.81	14.77
	006	1.30	21.3	10.13	38.3	8.84	33.4	7.63	28.8	2.40	1.78	14.28	10.64	23.79	17.74
	008	1.61	26.4	12.55	47.4	11.26	42.6	10.05	37.9	2.54	1.89	17.11	12.75	28.75	21.43
	010	2.08	34.1	16.22	61.3	14.93	56.4	13.71	51.8	2.76	2.06	21.38	15.94	36.22	27.00
	012	2.26	37.1	17.64	66.7	16.35	61.8	15.14	57.2	2.84	2.11	23.05	17.18	39.14	29.18
	014	2.81	46.0	21.88	82.7	20.59	77.8	19.37	73.2	3.09	2.30	27.99	20.87	47.78	35.62
	015	3.08	50.5	23.99	90.7	22.83	86.3	21.56	81.5	3.21	2.40	30.30	22.60	51.36	38.30
	017	3.56	58.3	27.73	104.8	26.44	99.9	25.22	95.3	3.43	2.55	34.81	25.95	59.73	44.54
	020	3.89	63.8	30.34	114.7	29.05	109.8	27.84	105.2	3.58	2.66	37.86	28.23	65.07	48.52
	022 <sup>4)</sup>	4.29	70.3	33.43	126.4	32.14	121.5	30.93	116.9	3.76	2.80	41.47	30.92	71.38	53.22
	025 <sup>3,5)</sup>	4.84	79.3	37.71	142.5	36.42	137.6	35.21	133.1	4.01	2.99	46.46	34.64	80.12	59.74
	028 <sup>3,6)</sup>	5.42	88.8	42.23	159.6	40.94	154.7	40.32	152.4	4.27	3.18	51.74	38.58	76.73	57.22
	031 <sup>3,6)</sup>	6.10	100.0	47.56	179.7	46.27	174.9	45.65	172.5	4.58	3.41	57.95	43.21	86.06	64.17

1) 085 = 90 bar (1300 psi) max. int. 2) 085 = 2000 RPM max. 3) 025-028-031 = 2500 R.P.M. max. 4) 022 = 275 bar max. int.  
5) 025 = 240 bar max. int. 6) 028-031 = 210 bar max. int. -- Not recommended to use as the internal leakage is over 50 of theoretical flow.