

VT67DB W - 038 - B08 1 R 00 - A 1 M1 -

Series- SAE C 2 bolts
Mounting flange J744c

severe duty shaft only

Cam ring for "P1"

Volumetric displacement cm³/rev (in³/rev)

*014/B14 = 47.6 (2.90)	035/B35 = 111.0 (6.77)
017/B17 = 58.2 (3.55)	038/B38 = 120.3 (7.34)
020/B20 = 66.0 (4.03)	042/B42 = 136.0 (8.30)
024/B24 = 79.5 (4.85)	045/B45 = 145.7 (8.89)
028/B28 = 89.7 (5.47)	050/B50 = 158.0 (9.64)
031/B31 = 98.3 (6.00)	061/B61 = 190.5 (11.62)

*0' - Uni - directional B' - Bi - directional

Cam ring for "P2"

Volumetric displacement cm³/rev (in³/rev)

B02 = 5.7 (0.35)	B09 = 28.0 (1.71)
B03 = 9.8 (0.60)	B10 = 31.8 (1.94)
B04 = 12.8 (0.78)	B11 = 34.9 (2.13)
B05 = 15.9 (0.97)	B12 = 40.9 (2.50)
B06 = 19.8 (1.21)	B14 = 45.1 (2.75)
B07 = 22.5 (1.37)	B15 = 50.0 (3.05)
B08 = 24.9 (1.52)	

Modifications

Mounting W/connection variables

P1=1-1/4" P2=3/4" S=3"	
UNC	METRIC
11	M1

Seal class

- 1 - S1 (for mineral oil)
- 4 - S4 (for fire resistant fluids)
- 5 - S5 (for mineral oil and fire resistant fluids)

Design letter

Porting combination (see page BM-1-5)

00 - standard

Direction of rotation

(view on shaft end)

- R - clockwise
- L - counter-clockwise

Type of shaft

- 1 - keyed (SAE C)
- 2 - keyed (no SAE)
- 3 - splined (SAE C)
- 4 - splined (no SAE)

Sever duty (VT67DBW only)

5 - keyed (no SAE)

VP
DP

INTERNAL LEAKAGE (TYPICAL)

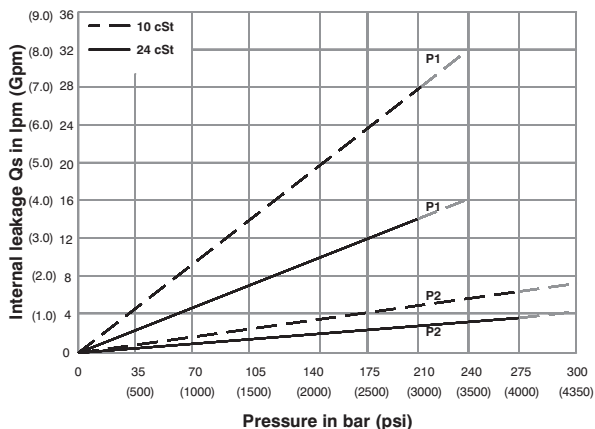

Do not operate pump more than 5 seconds at any speed or viscosity if internal leakage is more than 50% of theoretical flow. Total leakage is the sum of each section loss at its operating conditions.

NOISE LEVEL (TYPICAL)

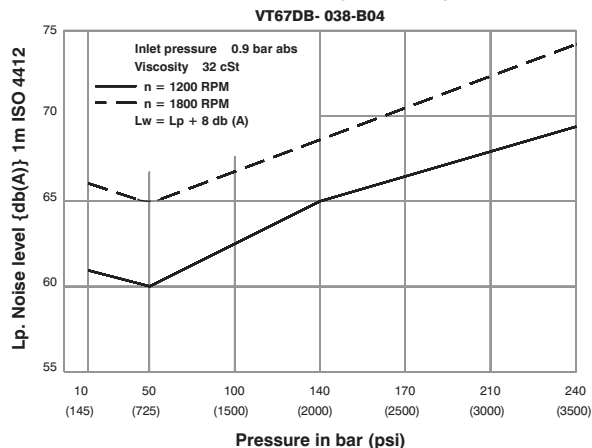

Double pump noise level is given with each section discharging at the pressure noted on the curve.

HYDROMECHANICAL POWER LOSS (TYPICAL)

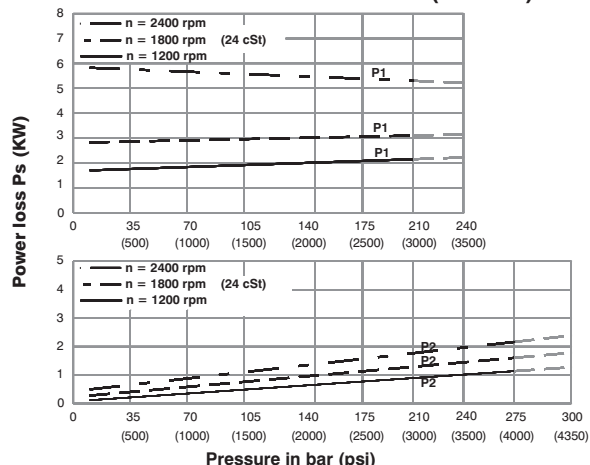

Total hydromechanical power loss is the sum of each section at its operating conditions.

PERMISSIBLE RADIAL LOAD

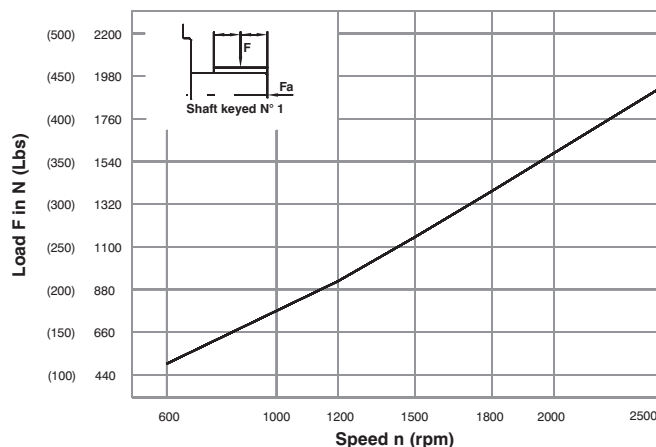

Maximum permissible axial load Fa = 1200 N (270 Lbs)

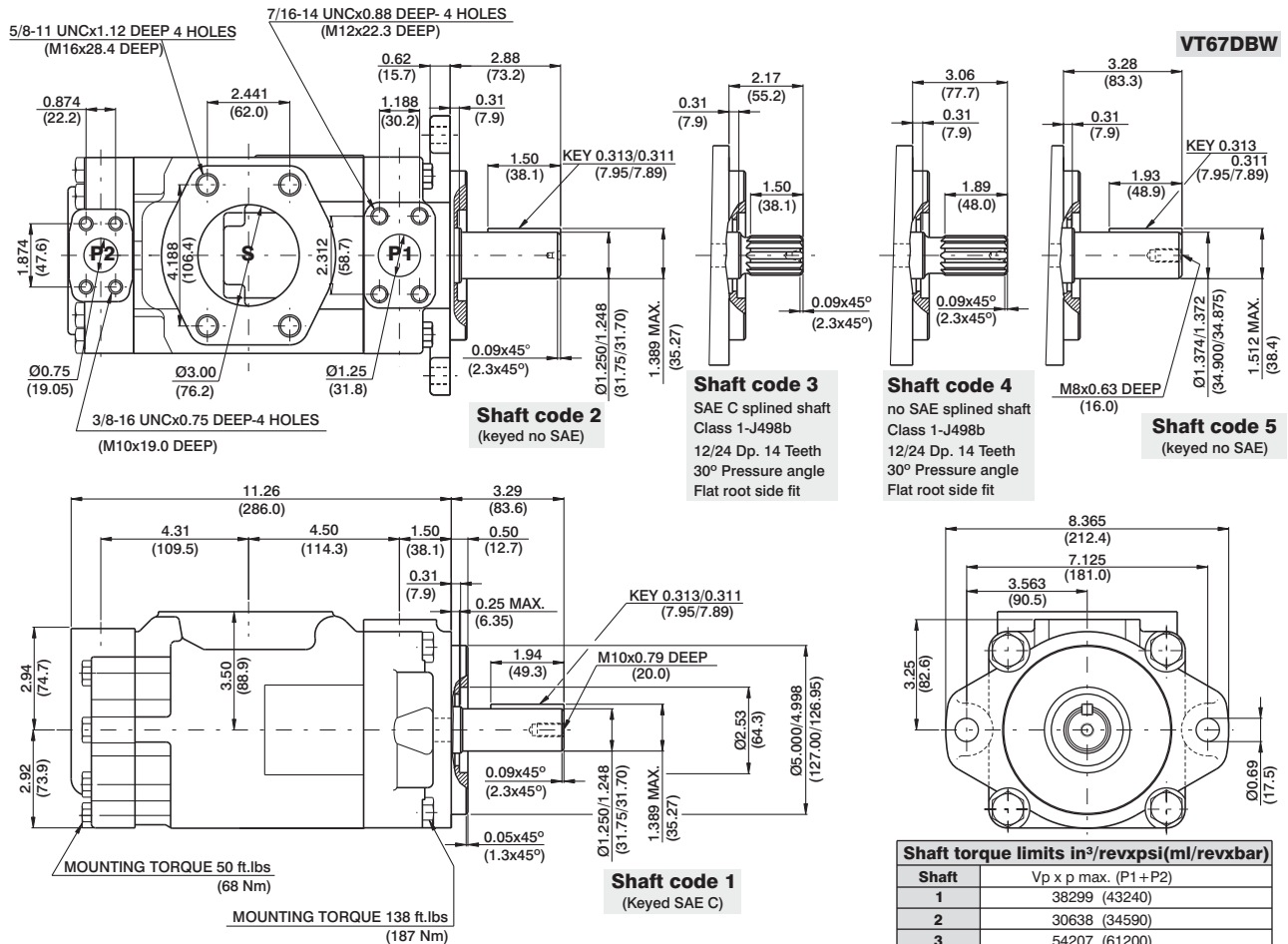

OPERATING CHARACTERISTICS - TYPICAL (24 cST) (Input power p (KW) for one cartridge only)

Pressure port	Series	Volumetric Displacement Vp		Flow q & n = 1800 rpm						Input power p & n = 1800 rpm					
		in ³ /rev	cm ³ /rev	p = 0 bar (0 psi)		p = 140 bar (2000 psi)		p = 240 bar (3500 psi)		p = 7 bar (100 psi)		p = 140 bar (2000 psi)		p = 240 bar (3500 psi)	
				gpm	lpm	gpm	lpm	gpm	lpm	hp	kw	hp	kw	hp	kw
P1	014	2.90	47.6	22.64	85.0	20.46	77.4	18.8	71.1	4.02	2.99	29.31	21.85	49.34	36.79
	017	3.55	58.2	23.1	87.3	20.6	78.0	18.99	71.8	3.35	2.5	29.77	22.2	49.62	37.0
	020	4.03	66.0	31.39	118.6	29.29	101.4	27.57	104.2	4.53	3.38	39.52	29.47	67.21	50.11
	024	4.85	79.5	37.81	142.8	35.63	134.6	33.99	128.5	4.91	3.66	47.02	35.06	80.32	59.89
	028	5.47	89.7	42.66	161.3	40.48	153.0	38.84	146.8	5.19	3.87	52.68	39.28	90.23	67.28
	031	6.00	98.3	46.75	176.7	44.57	168.5	42.93	162.3	5.43	4.09	57.45	42.84	98.58	73.51
	035	6.77	111.0	52.79	199.6	50.61	191.3	48.97	184.1	5.78	4.31	64.50	48.09	110.91	82.70
	038	7.34	120.3	57.21	216.3	55.03	208.1	53.39	201.8	6.04	4.50	69.66	51.94	111.94	83.47
	042 ¹⁾	8.30	136.0	64.68	244.5	62.50	236.3	60.86	230.1	6.47	4.83	78.37	58.44	135.19	100.81
	045 ¹⁾	8.89	145.7	69.29	261.9	67.11	253.7	65.47	247.5	6.74	5.02	83.75	62.45	144.61	107.83
	050 ^{1,2)}	9.64	158.0	75.14	284.1	72.96	275.8	71.78	271.3	7.08	5.27	90.58	67.54	134.54	100.32
061 ^{1,2)}	11.62	190.4	75.6	285.8	73.54	278.0	--	--	7.37	5.50	97.49	72.69	--	--	
P2				p = 0 bar (0 psi)		p = 140 bar (2000 psi)		p = 300 bar (4350 psi)		p = 7 bar (100 psi)		p = 140 bar (2000 psi)		p = 300 bar (4350 psi)	
	B02	0.35	5.8	2.76	10.4	2.33	8.8	1.80	6.8	0.74	0.55	4.02	2.99	8.10	6.40
	B03	0.60	9.8	4.66	17.6	4.23	15.9	3.70	14.0	0.85	0.63	6.24	4.65	12.93	10.25
	B04	0.78	12.8	6.09	23.0	5.66	21.4	5.13	19.4	0.94	0.70	7.90	5.89	16.55	13.13
	B05	0.97	15.9	7.56	28.6	7.13	26.9	6.60	25.0	1.02	0.76	9.62	7.17	20.29	16.12
	B06	1.21	19.8	9.42	35.6	8.99	33.9	8.46	32.0	1.13	0.84	11.79	8.79	25.00	19.88
	B07	1.37	22.5	10.70	40.4	10.27	38.8	9.74	36.8	1.20	0.89	13.29	9.91	28.26	22.47
	B08	1.52	24.9	11.84	44.7	11.41	43.1	10.88	41.1	1.27	0.94	14.62	10.90	31.15	24.78
	B09	1.71	28.0	13.31	50.3	12.87	48.6	12.35	47.0	1.36	1.01	16.35	12.19	34.92	27.77
	B10	1.94	31.8	15.12	57.2	14.69	55.5	14.16	53.5	1.46	1.11	18.45	13.75	39.48	31.42
	B11 ⁴⁾	2.13	34.9	16.64	62.9	16.19	61.2	15.68	59.3	1.55	1.15	20.17	15.04	43.22	32.22
	B12 ⁴⁾	2.50	40.9	19.50	73.7	19.07	72.1	18.54	70.1	1.72	1.28	23.55	17.56	50.58	37.71
	B14 ⁴⁾	2.75	45.1	21.40	80.8	20.95	79.2	20.44	77.0	1.83	1.36	25.80	19.23	55.48	41.37
	B15 ⁴⁾	3.05	50.0	23.78	89.8	23.35	88.3	22.88	86.5	1.97	1.47	28.55	21.28	57.35	42.76

1) 042-045-050-061 = 2200 RPM max. 2) 050 = 210 bar (3000 psi) max. int. 3) 061 = 120 bar (1740 psi) max. int, 061 = 80 bar (1160 psi) cont.

4) B11-B12-B14 = 300 bar (4350 psi) & B15 = 280 bar (4060 psi) max. int. And Max. Speed = 3000 rpm

Note: Product details are liable to change without any notice